

# On the Semantics of Denominal Adjectives

Bernard Fradin

*Laboratoire de linguistique formelle*  
 CNRS & University of Paris 7 Denis Diderot  
 bernard.fradin@linguist.jussieu.fr

## 1. Introduction

Denominal adjectives are complex adjectives morphologically constructed on a nominal basis, the base noun (abbreviated here as BseN). They can be formed by many different derivational processes as tableau1 attests for French.

Tableau 1. Varieties of denominal adjectives

SFX	BseN	Gloss	A	Gloss
-AIN	<i>Afrique</i>	‘Africa’	<i>africain</i>	‘African’
-É	<i>iode</i>	‘iodine’	<i>iodé</i>	‘iodized’
-EL	<i>an</i>	‘year’	<i>annuel</i>	‘annual’
-ESQUE	<i>Dante</i>	‘Dante’	<i>dantesque</i>	‘Dantesque’
-EUX	<i>lait</i>	‘milk’	<i>laiteux</i>	‘milky’
-IEN	<i>caméléon</i>	‘chameleon’	<i>caméléonien</i>	‘chameleonic’
-IN	<i>opale</i>	‘opal’	<i>opalin</i>	‘opalin’
-IQUE	<i>basalte</i>	‘basalt’	<i>basaltique</i>	‘basaltic’
-U	<i>branche</i>	‘branch’	<i>branchu</i>	‘branched’

If we classify adjectives according to the classical distributional criteria given in tableau 2, we see that denominal adjectives range in several distinct subclasses, as shown in tableau 3.

Tableau 2. Distributional criteria for A classification

Predicative position	NP COPULA A	<i>Jane (is + became) sad</i>
Prenominal position	A N	<i>big tree</i>
Postnominal position	N A	<i>stars visible</i>
Gradable	DEG A	<i>very angry / completely full</i>

Tableau 3. Adjectival subclasses

	(Aa)	(Ab)	(Ba)	(Bb)	(Ca)	(Cb)
1. Pred.	–	–	+	+	+	+
2. A N	–	–	–	–	–	+
3. N A	+	+	+	+	+	+
4. Grad.	–	–	–	–	+	+
5. Denom.	–	+	–	+	+	+

Examples : (Aa) *cadet* ‘cadet’, (Ab) *présidentiel* ‘presidential’, (Ba) *borgne* ‘one-eyed’,

(Bb) *mensuel* ‘monthly’, (Ca) *pansu* ‘paunchy’, (Cb) *courageux* ‘courageous’, *léger* ‘light’.

In tableau 3, denominal adjectives have value ‘+’ for property 5 ‘denominal’. All denominal adjectives occur in the postnominal attributive structure. The denominal adjectives I am interested in here are true relational adjectives, namely those in (Ab), which cannot occur in a predicative position e.g. *\*La voiture garée là-bas est présidentielle* ‘the car parked over there is presidential’. This property sets them apart from other subgroups of denominal adjectives, inasmuch as the latter can appear after the copula (cf. (Bb), (Ca), (Cb)). Moreover, denominal adjectives of type (Cb), e.g. *osseux* ‘bony’, may shift from one group to another in function of the semantic relationship existing between the noun which heads the NP (the head noun, HdN) and the base noun. For instance, while *osseux* behaves like a relational adjective in (1), it behaves like a plain predicative A, e.g. *léger* ‘light’, in (2).

- |     |    |                                     |   |
|-----|----|-------------------------------------|---|
| (1) | a. | <i>tuberculose osseuse</i>          | ‘bone tuberculosis’                         |
|     | b. | <i>*tuberculose très osseuse</i>    | ‘very bone tuberculosis’                    |
|     | c. | <i>?*sa tuberculose est osseuse</i> | ‘his tuberculosis is (a) bone tuberculosis’ |
| (2) | a. | <i>visage osseux</i>                | ‘bony face’                                 |
|     | b. | <i>visage très osseux</i>           | ‘very bony face’                            |
|     | c. | <i>son visage est osseux</i>        | ‘his face is bony’                          |

The reason why I limit myself to adjectives (Ab) of tableau 3 is that their properties place them at one end of the scale on which denominal adjectives can be ranked, the other end being occupied by adjectives like *courageux*, which do not differ from ordinary descriptive adjectives. Adjectives such as *mensuel* ‘monthly’ and *pansu* ‘paunchy’, on the other hand, occupy positions in-between since they also share properties of ordinary adjectives. To that extent, relational adjectives (Ab) appear to be more typical denominal adjectives than the other ones. In my opinion, it is easier to describe typical specimens of a category than less typical ones.

The scope of this article is to account for the interpretation of denominal adjectives in a postnominal position. In section 2, after reviewing general properties of denominal adjectives, I discuss some existing analyses and examine possible mechanisms in charge of their interpretation. Section 3 proposes such a mechanism for two standard cases, one where the denominal adjective exhibits an eventive reading and the other where we have a spatial reading. The last sections deal with more complex cases. Section 4 focuses on prefixed denominal adjectives such as *pré-électoral* ‘pre-election’ and section 5 extends the analysis to morphologically underived adjectives such as *intergalactique* ‘intergalactic’.

## 2. General properties of denominal adjectives

### 2.1. Morphological structure

I assume that denominal adjectives have the structure exemplified in figure 1, couched here in a typed-feature formalism (cf. Sag & Wasow 1999). *A-den* (denominal adjective) notes the lexical type of the adjective. Feature MORPH-ST (Morphological structure), whose value is a sign, gives the structure of the N which is the base of the adjective. Schematic though it is, the structure of fig. 1 notes two important properties

of denominal adjectives. First, the fact that their phonology (PHON) is equivalent to the concatenation of the phonology of the base with a suffix (chosen among those mentioned in tableau 1). Second, the fact that the semantics of the derived adjective is the same as the semantics of its base noun. This is expressed through the shared value [2] of the feature REL (RELATION), itself a value of the feature CONT (CONTENT). Figure 2 gives the schematic representation of the denominal adjective PRÉSIDENTIEL.<sup>1</sup>

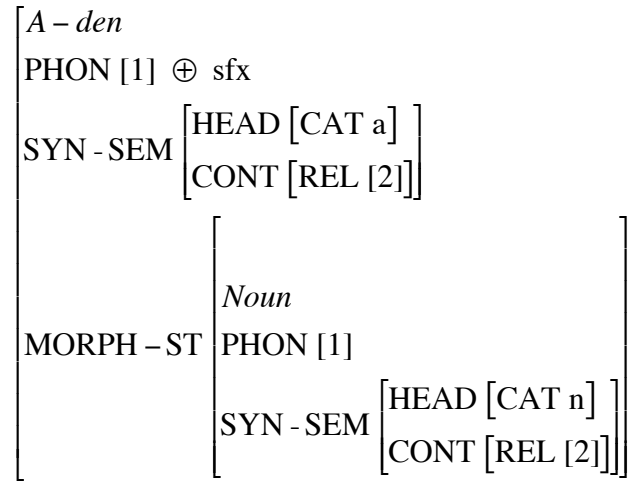

Figure 1. Structure of denominal adjectives

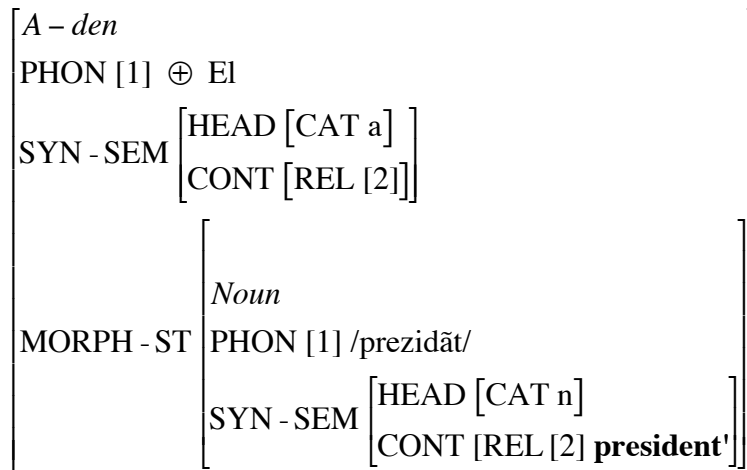

Figure 2. Structure of adjective *présidentiel*

## 2.2. The semantics of relational adjectives

As the above-mentioned representations state, relational adjectives are semantically transparent. I contend that their only semantic import is to indicate that their base noun is a potential argument of a semantic relation R. Two views exist as regards relation R : a purely contextual one and a mixed one.

The contextual approach claims that R's value is always supplied by the context. It has been argued for by Mezhevich (2004) and endorsed by several other researchers (McNally & Boleda 2004). On this view, expression (3a) receives semantic representation (3b) and the value of R is contextually determined.

<sup>1</sup> On the apparition of the semi-vowel /j/, see Thornton (1999).

- (3) a. *presidential adviser*  
 b.  $(\lambda x. \mathbf{adviser}'(x) \wedge \mathbf{R}(x, \mathbf{president}'))$

The mixed approach says that either the semantic representation of either HdN or BseN can provide us with R. Otherwise, or in addition, the relation is supplied by the context (the default option). For instance, if we assume that (4b) is the representation associated with (4a), any of the predicates mentioned in (4c) can be used to instantiate R. Predicates **live-in'** and **build'** come from the semantic representation associated to *palace* (cf. below), while **possess'** would be a default relation triggered by the animacy of the BseN's referent.

- (4) a. *palais présidentiel* 'presidential palace'  
 b.  $T(\textit{palais présidentiel}) = (\lambda x. \mathbf{R}(x, y) \wedge \mathbf{palace}'(x) \wedge \mathbf{president}'(y))$   
 c.  $\mathbf{R} = \{\mathbf{live-in}', \mathbf{build}', \mathbf{possess}' \dots\}$

What are the arguments supporting one approach rather the other? The next subsection discusses this issue and is devoted to the survey of Mezhevich's position.

### 2.3. Mezhevich's point of view

Mezhevich's argumentation is articulated in three points. On the basis of data like (5), she first argues that the values of R in constructs with a denominal adjective (DA constructs)<sup>2</sup> seem arbitrary and that their range is potentially unlimited.

- (5) a. *moloč-n-yj* *magazin*  
 milk-AZR-M.SG store:M:SG  
 'store that sells dairy products'  
 b. *moloč-n-aja* *ferma*  
 milk-AZR-F.SG farm:F:SG  
 'farm that products dairy products'  
 c. *moloč-n-yj* *stakan*  
 milk-AZR-M.SG glass:M:SG  
 'glass for milk'  
 d. *moloč-n-yj* *koktel*  
 milk-AZR-F.SG cocktail:M:SG  
 'milk cocktail'

We agree with Mezhevich that the range of readings allowed by denominal adjective is very wide, but this does not mean that the value of R is arbitrary. If it were such, any of the DA construct above could show any of the attested reading, which is not true. For instance, normally, (5c) cannot mean 'glass made of milk', or (5b) 'store that products dairy products' because of the meaning attached to *stakan* and *magazin*. Secondly, she states that R's value crucially depends on the meaning of HdN, BseN and the knowledge of the world. But she adds, third point, that the arbitrariness of the relation makes it more dependent on the contextual knowledge. Example (6) is a case in point,

<sup>2</sup> Denominal adjective constructs (DAC) are incomplete NPs with a DA (NPDA) e.g. *palais présidentiel*. They are incomplete in French because they lack a determinant.

since it clearly exhibits a purpose relation whereas, according to Mezhevich, neither *zamok* ‘lock’ nor *skvažina* ‘hole’ expresses a relation of purpose.

- (6)            *zamoč-n-aja*    *skvažina*  
                   lock-AZR-F.SG   hole:F:SG  
                   ‘keyhole’

Point 2 is true, but point 3 lacks compelling support. *Skvažina* seems to denote a hole dug on purpose as examples (7) show, whereas other Russian translation of *hole* e.g. *dyra* ‘hole’, *jama* ‘pit, hole’, *ščel’* ‘chink, crack, slit’, *otverstie* ‘slot, opening’ are not so overtly telic. The first three generally denote holes the existence of which results from natural causes.

- (7)    a.    *nefta-n-aja*            *skvažina*  
                   oil-AZR-F.SG            hole:F:SG  
                   ‘oil well’  
       b.    *bur-ov-aja*            *skvažina*  
                   drill-AZR-F.SG        hole:F:SG  
                   ‘drill well’

The same reasoning extends to other examples of (5), since all HdNs thereof denote a functional-artefact (store, glass, farm).

Jensen and Vikner’s experiment on genitive interpretation suggests another argument in favor of the idea that, in most cases, relation R can be recovered from the interaction of HdN and BseN’s meanings and that making use of the context to find an adequate pragmatic interpretation is a last resort strategy, not a basic strategy. In their paper (Jensen & Vikner 2002), Jensen and Vikner report an experiment they performed on the interpretation of genitive phrases such as **the N of N**, **the N’s N**, etc. In a corpus of fictional and non fictional texts in English, they found 2,333 genitive forms, of which only 9 had a pragmatic interpretation. As an example of pragmatic interpretation, they give the phrase “the deaf mute’s pen” which had to be interpreted as ‘the pen he had bought from the deaf mute’ in the book’s context. The very low rate of contextual interpretation is at odds with the view that it is the basic interpretive strategy. As has often been stressed (Partee & Borschev 2003, 2001), the problems of interpretation raised by NPDA’s are akin to those raised by genitives, which makes Jensens and Vikner’s finding relevant for the present discussion. It remains clear however that a conclusive argument about the interpretation of denominal adjective hinges on checking their interpretation on corpora in French through experiments similar to the one carried out by Jensen and Vikner. I leave this task for future research.

The third argument that can be put to the fore against a purely contextual approach is tied to the contrast between (1) *visage très osseux* and (2) *\*tuberculose très osseuse*. The point is that this contrast in grammaticality is determined only on the basis of information supplied by the HdN and the BseN (Fradin 2007, 2008 (to appear)). This downplays the role of context in the story, since we can do without it in this latter case.

To sum up, the mixed approach, according to which relation R is established on the basis of the meaning of both the HdN and the BseN on the one hand, and the context on the other hand whenever needed, seems heuristically more promising and will be adopted here.

## 2.4. The semantic mechanism for DAs interpretation

Since denominal adjectives limit themselves to transmitting the semantic content of their BseN at an upper level, their interpretation takes place at the level of the NP in which they occur, or, more appropriately, at the level of the denominal adjective construct, which corresponds to the lexematic (underlined) constituents in (8) (alternative analyses concerning the realisation of *la* in *l'élection* can be proposed, but they have no bearing on the point under discussion).

(8) [NP [DET *la*] [NP [N *élection*][A-DEN *présidentielle*]]

The semantic interpretation rule is triggered by the feature A-DEN (denominal adjective) and varies in function of the information associated both to the HdN and the relational A. Relation R is usually instantiated by a predicate supplied either by the HdN or the BseN, the choice between them depending on the semantic sort of these units.

The DA's semantic mechanism shows two important properties. The first one is rule sensibility. I assume that Ns can be classified in function of their semantic properties and that the semantic nature of the N is noted by a feature. The features indicate, for instance, whether the HdN denotes an event, an artefact, an individual, etc., or whether the BseN denotes an object, a place, an agent, etc. This device allows us to adjust the instruction associated with the semantic rule, which changes in function of the feature combination involved. The second property is rule peeking: the semantic rules use information located inside the HdN or the BseN's semantic representation. This idea is not new and has been put in application since Pustejovsky's qualia at least.

I will assume that the semantic information involved in semantic rules comes from two different sources: surface level (or external meaning) and lexical level (or internal meaning cf. Pustejovsky's qualia). The external meaning is the semantic translation of the syntactic units that form sentences (cf. (9)). The internal meaning corresponds to lexically encoded information and usually lacks any syntactic correlate in the sentence (cf. (10)). Note however that standard formal semantics approaches, as Dowty (1979) for instance, do not allow using internal meaning.<sup>3</sup> What makes such a move licit here, I would suggest, is the presence of the denominal adjective in the construction.

(9) a.  $T(\text{HOUSE}) = (\lambda x. \mathbf{house}'(x)) = \mathbf{house}'$   
 b.  $T(\text{FATHER}) = (\lambda x. \lambda y. \mathbf{father}'(x,y)) = \mathbf{father}'$   
 c.  $T(\text{ELECTION}_{\text{EXT}}) = (\lambda x. \mathbf{election}'(x)) = \mathbf{election}'$

(10) a.  $T(\text{ELECTION}_{\text{INT}}) = (\lambda y. \lambda x. \lambda e. \mathbf{elect}'(e,y,x))$   
 b.  $T(\text{MAGAZIN}_{\text{INT}}) = (\lambda z. \lambda y. \lambda x. \lambda e. \mathbf{sell}'(e,y,x) \wedge \text{LOC}(\mathbf{in}'(z),e))$

The values taken by relation *R* can be subsumed under three types: eventive, spatial, and equative. As I said before, the choice between one type or the other hinges on the semantic content associated to the HdN or BseN. Tableau 4 gives a synopsis of the main cases we can come across. Only cases in bold will be dealt with in the present study. To give just a hint about the equative type, I would say that it corresponds to readings such as 'fishing that is (an instance of) industry' or 'wrought iron that is (an instance of) art'

<sup>3</sup> Many thanks to Patrick Caudal, who reminded me of this point.



- cii.  $(\lambda y. \lambda e. \exists x. \mathbf{elect}'(e,y,x))$  agent reading (cf. (11b))
- (15) a.  $T(\text{PRÉSIDENTIEL}) = \mathbf{president}'$   
 b.  $T(\text{POPULAIRE}) = \mathbf{people}'$

The rule which interprets the structure at the level of the (incomplete) NP is (16), where  $N_{EV}$  corresponds to the internal semantic representation of the eventive noun. As clause (16b) makes it clear, the rule also stipulates to what semantic translation  $N_{EV}$  corresponds.

- (16) NP's interpretation rule 1  
 a.  $T(N_{EV} A_{DEN}) = (\lambda N_{EV}. \lambda A. \lambda e. \lambda z. N_{EV}(e,z,\dots) \wedge A(z))$   
 b.  $N_{EV} = T_{INT}(N_{EV})$

Insofar as *ÉLECTION* has two internal semantic representations, the rule yields two interpretations. The first one is given in (17) and corresponds to the patient reading ('an event  $e$  such that an  $y$  has the property that there is an  $x$ , who is president, such the  $y$  elects  $x$ '); the second one is (18) and corresponds to the agent reading ('an event  $e$  such an  $y$  has the property that there is an  $x$  that elects  $y$ ' and  $x$  is people).

- (17)  $T(\text{ÉLECTION PRÉSIDENTIELLE})$   
 $= (\lambda N. \lambda A. \lambda y. \lambda e. \exists x. N(e,y,\dots) \wedge A(x))(N_{INT-A})(A)$   
 $= (\lambda y. \lambda e. \exists x. \mathbf{elect}'(e,x,y) \wedge \mathbf{president}'(x))$  (cf. (11a))
- (18)  $T(\text{ÉLECTION POPULAIRE})$   
 $= (\lambda N. \lambda A. \lambda y. \lambda e. N(e,\dots,x) \wedge A(x))(N_{INT-B})(A)$   
 $= (\lambda y. \lambda e. \exists x. \mathbf{elect}'(e,y,x) \wedge \mathbf{people}'(x))$  (cf. (11b))

Cautious readers might have noticed however that interpretation (17) is flawed, since it says that an  $x$  who is a president has been elected, while (11a) means instead that an  $x$  has been elected and the result is that he became a president, i.e. something more akin to ' $(\lambda x. \lambda e. \exists z. \mathbf{elect}'(e,z,x) \wedge \mathbf{result}'(e, \mathbf{president}'(z)))$ '. Since my point here is to show how to deal with the difference between the agent vs. patient reading more than to give an exact account of the meaning of *élection présidentielle*, I will leave this issue aside.<sup>4</sup>

As for the DA construct *carte routière* 'road map', the link between the HdN and the BseN is also provided by the HdN. The semantic translation of *ROUTIER*, given in (19), corresponds to the external meaning of the lexeme, while that of *CARTE* 'cart' in (20) involves two internal meanings in addition to the external meaning. Both of them stem from the fact that this lexeme denotes a functional-artefact. They correspond to the Origin and Telic qualia in Pustejovsky (1995). The Origin quale says that a map is an

<sup>4</sup> Actually, the content of the internal semantic representation (14ci) has to be changed and so has to be the rule interpreting the NP. In the reading in question, *ÉLIRE* 'elect' creates a juridical state (on a par with *JUGER* 'judge', for example) and the rule must be devised in such a way that it could cope with all verbs of this type. It should be noted that example (13) shows that argument  $y$  in the agent reading (18) can be saturated by a *de* PP at the NP level. However, no saturation is possible with a denominal A: (a) *\*élection (populaire présidentielle + présidentielle populaire)* is out and cannot mean 'election of the president by (the) people'. The situation is worse for the patient reading: (b) is ungrammatical and (c) cannot mean 'election of the president by French' but only 'election of the president (that takes place) in France': (b) *\*élection présidentielle des Français*, (c) *élection présidentielle française*.

object which emerges through printing and the Telic quale tells us that it is a semiotic object, since it provides a representation of something.

$$(19) \quad T(\text{ROUTIER}) = (\lambda x. \mathbf{road}'(x)) = \mathbf{road}'$$

- (20) a.  $\text{SORT}(\text{CARTE}) = o \wedge \text{functional-artefact (fct-art)}$   
 b.  $T_{\text{EXT}}(\text{CARTE}) = (\lambda x. \mathbf{map}'(x)) = \mathbf{map}'$   
 c.  $Q_{\text{ORI}}(\text{CARTE}) = (\lambda x. \lambda y. \lambda e. \mathbf{print}'(e,x,y))$   
 d.  $Q_{\text{TEL}}(\text{CARTE}) = (\lambda x. \lambda y. \lambda e. \mathbf{represent}'(e,x,y))$   
 condition: 'x is a geographical object'

With functional artefact of this kind, I suppose that the rule that combines the semantics of both the N and the denominal A at the NP level is something like (21). The source of the relation is, following the order of preference, the Telic or the Origin quale, and when neither proves suited, a contextual relation is sought for. Consequently, the interpretation of the NP *carte routière* is predicted to be (22), which is correct.

- (21) NP's interpretation rule 2  
 a.  $T(\text{N}_{\text{FCT-ART}} \text{A}_{\text{DEN}}) = (\lambda \mathbf{R}. \lambda \mathbf{N}. \lambda \mathbf{A}. \lambda y. \exists x. \mathbf{R}(e,x,y) \wedge \mathbf{N}(y) \wedge \mathbf{A}(x))$   
 b.  $\mathbf{R} = Q_{\text{TEL}}(\mathbf{N}) > Q_{\text{ORI}}(\mathbf{N}) > \text{contextual}$

$$(22) \quad T(\text{CARTE ROUTIÈRE}) = (\lambda y. \exists x. \mathbf{represent}'(e,x,y) \wedge \mathbf{map}'(y) \wedge \mathbf{road}'(x))$$

### 3.2. The spatial interpretation

If we consider now the slightly different DA construct *carte murale*, we see that the source of the relation shifts from the HdN to the BseN, inasmuch as there is no sense in which we can say that a map is designed to represent a wall. And it is so because MUR (or WALL) does not denote a geographical object. If we look at the semantic representation of WALL, we can arguably claim that it contains information relative to the constitution of its referent ('continuous vertical (brick or stone) structure...' cf. quale Aspect in Pustejovsky), its function ('... structure that encloses or divides an area or supports a load' cf. quale Telic) and, obviously, its Origin since it denotes an artefact. This gives us a partial representation like (23) for the semantics of WALL / MUR.

- (23) a.  $\text{SORT}(\text{MUR}) = o \wedge \text{functional-artefact}$   
 b.  $T_{\text{EXT}}(\text{MUR}) = (\lambda x. \mathbf{mur}'(x)) = \mathbf{mur}'$   
 c.  $Q_{\text{TEL}}(\text{MUR}) = (\lambda x. \lambda y. \lambda e. \mathbf{enclose}'(e,x,y) \wedge \mathbf{area}'(x) \dots )$   
 d.  $Q_{\text{ORI}}(\text{MUR}) = (\lambda x. \lambda y. \lambda e. \mathbf{build}'(e,x,y))$

Since WALL quite regularly denotes a space corresponding to a Ground in a spatial relationship e.g. *painting on the wall, nail in the wall*, I would argue that its semantics may be supplemented by the spatial relation indicated in (24a). This relation can be seen as a default relation available whenever none of the internal meanings provides a suitable relation. It may appear with all nouns denoting an object that can easily be interpreted as a Ground e.g. *table, roof, tree*, etc. A general formulation of this relation is proposed in (24b), where **adloc**' notes the semantics of a locative adposition.

- (24) a.  $T_{\text{SPATIAL}}(\text{MUR}) = (\lambda x. \lambda y. \text{LOC}(\mathbf{on}'(x),y))$   
 condition: 'x has a spatial extension'

- b.  $T_{\text{SPATIAL}}(\text{N}) = (\lambda x. \lambda y. \text{LOC}(\mathbf{adloc}'(x), y))$   
 where  $y$  range over events or entities.

I suppose that whenever this relation is chosen, the N is given the subtype ‘Space Noun’. I further assume that denominal adjectives based on spatial nouns are specified as such by the morphological rule that builds them (cf. (25a)) and that they receive two semantic translations. The ordinary one, which corresponds to their being denominal (cf. (25b)), and another one, qua spatial denominal, which is equivalent to the spatial representation of the BseN (cf. (25c)). This amounts to say that the denominal A inherits from its base N the capacity to function as a Ground in case the latter possesses this capacity.

- (25) a.  $\text{mural}_{\text{SPACE-DEN}} < \text{mur}_{\text{SPACE-NOUN}}$   
 b.  $T(\text{MURAL}) = (\lambda x. \mathbf{mur}'(x)) = \mathbf{mur}'$   
 c.  $T(\text{MURAL}_{\text{SPACE-DEN}}) = T_{\text{SPATIAL}}(\text{MUR})$

The semantic rule at the NPDA level is a variant of (21). Condition (26b) specifies that the relation is provided by the spatial relation associated to the base noun, if any (in the present case (24a)). Hence, the NP *carte murale* receives interpretation (27), which can be paraphrased by ‘map which has the property of being located on (a) wall’.

- (26) NP’s interpretation rule 3  
 a.  $T(\text{N } \mathbf{A}_{\text{SPACE-DEN}}) = (\lambda \mathbf{R}. \lambda \mathbf{N}. \lambda \mathbf{A}. \lambda x. \exists y. \mathbf{R}(y, x) \wedge \mathbf{N}(x) \wedge \mathbf{A}(y))$   
 b.  $\mathbf{R} = T_{\text{SPATIAL}}(\mathbf{BseN})$
- (27)  $T(\text{CARTE MURALE}) =$   
 $(\lambda \mathbf{R}. \lambda \mathbf{N}. \lambda \mathbf{A}. \lambda x. \exists y. \mathbf{R}(y, x) \wedge \mathbf{N}(x) \wedge \mathbf{A}(y))(\lambda x. \lambda y. \text{LOC}(\mathbf{on}'(x), y))(\mathbf{map}')( \mathbf{wall}' )$   
 $= (\lambda x. \exists y. \text{LOC}(\mathbf{on}'(y), x)) \wedge \mathbf{map}'(x) \wedge \mathbf{wall}'(y)$

The DA construct *élection professionnelle* ‘election (of representatives) within a profession’ will be interpreted in the same way, since *profession* ‘profession’ can be neither the agent, nor the patient in (14c) (nor a final state, by the way cf. note 2). Insofar as locative phrases such as (*il travaille*) *dans cette profession* ‘(he works) in this profession’, *au sein de cette profession* ‘within this profession’, etc. are possible, the suppletive semantic rule (24b) is available. The NP in question will get the interpretation ‘election which has the property of taking place within (a) profession(s)’.

This account of NPs involving a spatial interpretation allows us to tackle the more complex issue of prefixed denominal adjectives.

#### 4. Prefixed denominal adjectives

The phenomenon I would like to examine now is illustrated by the words in bold in examples (28):

- (28) a. *La cartographie de la pente de la surface par le satellite ERS permet de repérer les lacs **sous-glaciaires** (...) de l’Antartique. LE JOURNAL DU CNRS, N° 205-206, February-March 2007, p. 25.*  
 ‘The cartography of the surface slope by satellite ERS allows one to spot the lakes located under the glaciers (...) of Antartica.’

- b. (...) *un cru issu d'une vigne préphylloxérique* (...) *MARIANNE*, 15-21 September 2007, p. 95.  
 'a vine coming from a vineyard that existed before the epidemic of phylloxera' [in 1867]
- c. *Association Transfrontalière de Protection des Chauves Souris. Vereinigung Grenzüberschreitender Fledermausschutz.* (aptes.ciril.fr)  
 'cross-border association for bat protection'

I will discuss only the first case, *lac sous-glaciaire*. I suppose that the information given in (29)-(30) is part of the semantic representation associated to lexemes LAC / LAKE and GLACIER, respectively. Note that both can have the additional spatial meaning, since we have phrases like (*dans + sur*) *le lac* '(in + on) the lake', *sur le glacier* 'on the glacier'.

- (29) a.  $\text{SORT}(\text{LAC}) = o \wedge \text{natural-species (ntsp)}$   
 b.  $T_{\text{EXT}}(\text{LAC}) = (\lambda x. \text{lake}'(x)) = \text{lake}'$   
 c.  $T_{\text{SPATIAL}}(\text{LAC}) = (\lambda x. \lambda y. \text{LOC}(\text{in}'(x),y))$
- (30) a.  $\text{SORT}(\text{GLACIER}) = o \wedge \text{natural-species (ntsp)}$   
 b.  $T_{\text{EXT}}(\text{GLACIER}) = (\lambda x. \text{glacier}'(x)) = \text{glacier}'$   
 c.  $T_{\text{SPATIAL}}(\text{LAC}) = (\lambda x. \lambda y. \text{LOC}(\text{on}'(x),y))$

Contrary to what has been commonly assumed since Corbin (1987) and more specifically (Corbin 1990) (cf. Amiot 1997: 108-119), I contend that spatial / temporal prefixation directly apply to denominal adjectives (e.g. GLACIAIRE) and need not apply to a noun corresponding to the base noun (e.g. GLACIER). Very schematically, the derivation pattern for adjectives prefixed by SOUS- would be something like figure 3.

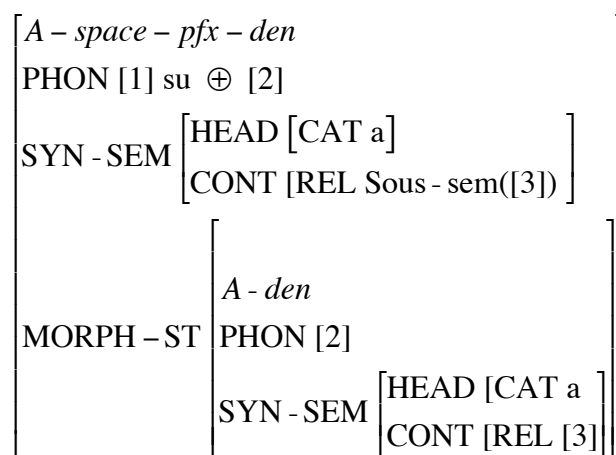

Figure 3. The rule schema for SOUS prefixation

At the phonological level, the segment /su/ is prefixed onto the phonology of the base e.g. /glasjɛʁ/ for *glaciaire*, which correctly yields *sous-glaciaire* /suglasjɛʁ/. At the semantic level, the semantic function associated with prefix SOUS- (noted Sous-sem in figure 3) is applied to the semantics of the denominal adjective, namely **glacier'**. This Sous-sem function corresponds to the translation of SOUS used as a spatial prefix (cf. (31)). In the case at hand, applying (31) to the semantics of GLACIAIRE yields the semantics of SOUS-GLACIAIRE (32).

$$(31) \quad T(\text{SOUS}_{\text{SPCE-PFX}}) = (\lambda Q. \lambda x. \lambda y. \text{LOC}(\mathbf{under}'(y),x) \wedge Q(y))$$

$$(32) \quad \begin{aligned} & T(\text{SOUS-GLACIAIRE}_{\text{SPCE-PFX-DEN}}) \\ &= (\lambda Q. \lambda x. \lambda y. \text{LOC}(\mathbf{under}'(y),x) \wedge Q(y))(\mathbf{glacier}') \\ &= (\lambda x. \lambda y. \text{LOC}(\mathbf{under}'(y),x) \wedge \mathbf{glacier}'(y)) \end{aligned}$$

As indicated in figure 3, spatial prefixations in SOUS-, TRANS-, INTRA-, INTER-, etc. confer type ‘space-prefixed’ (SPCE-PFX) on the derived adjective, which therefore becomes a ‘space-prefixed-denominal adjective’. At the NP level, the rule combining the semantics of this type of adjective with the HdN is a variant of interpretation rule (26). The variation comes down to the lack of variable **A**, which follows from the fact that the semantic content carried by **A** has already been incorporated into the semantics of the ‘space-prefixed-denominal’ adjective e.g. SOUS-GLACIAIRE. The application of (33) to the semantics of LAC gives us the interpretation of *lac sous-glaciaire*, namely (34) ‘a lake such that it is located under a glacier’.<sup>5</sup>

$$(33) \quad \begin{aligned} & \text{NP's interpretation rule 4} \\ & \text{a. } T(\mathbf{N} \mathbf{A}_{\text{SPCE-PFX-DEN}}) = (\lambda \mathbf{R}. \lambda \mathbf{N}. \lambda x. \exists y. \mathbf{R}(x,y) \wedge \mathbf{N}(x)) \\ & \text{b. } \mathbf{R} = T(\mathbf{A}_{\text{SPCE-PFX-DEN}}) \end{aligned}$$

$$(34) \quad \begin{aligned} & T(\text{LAC SOUS-GLACIAIRE}_{\text{SPCE-PFX-DEN}}) = \\ & (\lambda \mathbf{R}. \lambda \mathbf{N}. \lambda x. \exists y. \mathbf{R}(x,y) \wedge \mathbf{N}(x))(\lambda x. \lambda y. \text{LOC}(\mathbf{under}'(y),x) \wedge \mathbf{glacier}'(y))(\mathbf{lake}') \\ &= (\lambda x. \exists y. \text{LOC}(\mathbf{under}'(y),x) \wedge \mathbf{glacier}'(y) \wedge \mathbf{lake}'(x)) \end{aligned}$$

An account of prefixed temporal denominal adjectives e.g. *préphylloxérique*, *pré-électorale* ‘pre-election (N)’, etc. can be conceived along the same line, provided some adjustments required by the temporal nature of the prefix are made.

## 5. Non derived denominal adjectives

The lexemes listed in the left column of (35) are underived relational adjectives in French, which have been either inherited from Latin, or borrowed and adapted from Greek or other language.

$$(35) \quad \begin{array}{ll} \text{a.} & \text{TERRESTRE ‘terrestrial’} & < \text{Lat. } \textit{terrestris} \\ \text{b.} & \text{GALACTIQUE ‘galactic’} & < \text{Grk } \textit{\gamma\alpha\lambda\alpha\kappa\tau\iota\kappa\acute{o}\varsigma} \\ \text{c.} & \text{FRONTALIER ‘border (N)’} & < \text{Gasc. } \textit{frountalér} \end{array}$$

Yet they behave exactly like derived relational adjectives as attested by the grammatical contrasts shown in (36), which replicate what we saw with typical relational adjectives (Ab) (cf. Tableau 3).

$$(36) \quad \begin{array}{ll} \text{a.} & \textit{La sismologie terrestre} & \text{‘Earth’s seismology’} \\ \text{b.} & \textit{*La terrestre sismologie} \\ \text{c.} & \textit{*Cette sismologie est terrestre.} \\ \text{d.} & \textit{*La sismologie très terrestre} \end{array}$$

<sup>5</sup> The interpretation of the denominal adjectival construct *lac glaciaire* is completely different since the latter means something like ‘lake such that it exists because of glaciers’. The causal relation involved in this interpretation can be thought as an instantiation of the ORIGIN quale for objet that are not artefacts.

All these cases, which are very numerous, are obvious instances of suppletion. In the phonological rubric of the lexeme, a suppletive form is provided (*terrestre*, /tɛʁɛstʁ/; *galactique*, /galaktik/) instead of the expected suffixed form either, because no suffixation process of the type requested exists (e.g. no suffix /ɛstʁ/), or because the potential base does not belong to the stock of native French roots (e.g. °/galakt/, °/fɛʁʒɔ̃tal/ are not correlated to a nominal word-form in French). These suppletions account for the underived character of the adjectives in question. Underived though they are, these adjectives are semantically complex since they are correlated to a noun, and this is why they pattern like normal denominal adjectives. The mismatch between the phonology (simple) and the semantics (complex) exhibited by these lexemes is directly encoded in the representation proposed under figure 4 for GALACTIQUE.

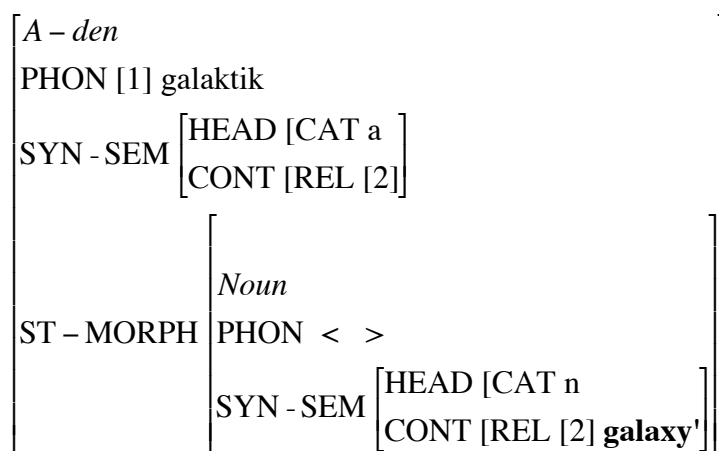

Figure 4. Structure of A *galactique*

From the point of view of semantics, the A is denominal (and therefore complex) insofar as its content is based upon the content of an existing noun. From the point of view of phonology, the A is simple since its phonology is not the result of adding a suffix to a base, inasmuch as there is no such base : the empty value of PHON attests that the form has been borrowed or inherited as a whole. For sure, the phonological ending may look like an existing suffix e.g. /ik/ in *basaltique* ‘basaltic’, *cyclique* ‘cyclic, cyclical’, etc., or /je/ in *lingagier* ‘linguistic’, *princier* ‘princely’, etc.<sup>6</sup> Or it may not, as is the case for /ɛstʁ/, which shows up in 7 lexemes only, all inherited from Latin.

The fact that the adjectives of (36) are semantically complex allows us to cope with the paradigmatic effect observed in (37).

- (37) a. *glacier / glaciaire / sous-glaciaire*  
 b. *galaxie / galactique / intergalactique*  
 c. *terre / terrestre / extraterrestre*

<sup>6</sup> Corbin calls this type of ending *intégrateur paradigmatique* ‘paradigmatic integrator’ (Corbin 1990). A paradigmatic integrator has the phonological appearance of a suffix but none of its other properties. It allows a form e.g. *peuplier* ‘poplar’ to join up a series of full-fledged derived forms e.g. *pommier* ‘apple-tree’, *prunier* ‘plum-tree’, etc. on the sole basis of the formal similarity it shares with other forms of the series. In a lexematic framework, the phenomenon paradigmatic integrators aim at capturing can be expressed without postulating this device. Suffices it to take advantage of the surface similarity exhibited by the forms in question (cf. Fradin 2003 : 140-145).

The adjectives in (37b-c) pattern in the same way as the one in (37a), even though they are not derived upon the base-noun mentioned on the left. On the model of what we had for prefix SOUS in (31), let us suppose that the spatial prefix INTER- has the semantics given in (38).

$$(38) \quad T(\text{INTER}_{\text{SPACE-PFX}}) = (\lambda Q. \lambda x. \lambda y. \text{LOC}(\mathbf{between}'(y),x) \wedge \mathbf{Q}(y))$$

GALACTIQUE is stored as a denominal adjective in the lexicon (cf. figure 4). Applying (38) to GALACTIQUE yields the interpretation given in (39).

$$(39) \quad \begin{aligned} & T(\text{INTER-GALACTIQUE}_{\text{SPACE-PFX-DEN}}) \\ & = (\lambda Q. \lambda x. \lambda y. \text{LOC}(\mathbf{under}'(y),x) \wedge \mathbf{Q}(y))(\mathbf{galaxy}') \\ & = (\lambda x. \lambda y. \text{LOC}(\mathbf{between}'(y),x) \wedge \mathbf{galaxy}'(y)) \end{aligned}$$

At the NP level, rule (33) straightforwardly derives interpretation (40) for *voyage intergalactique*, exactly as it did for *lac sous-glaciaire* ('a travel such that it [takes place] between galaxies').

$$(40) \quad \begin{aligned} \text{a.} \quad & T(\text{VOYAGE INTERGALACTIQUE}_{\text{SPACE-PFX-DEN}}) = \\ \text{b.} \quad & (\lambda \mathbf{R}. \lambda \mathbf{N}. \lambda z. \exists y. \mathbf{R}(z,y) \wedge \mathbf{N}(z))(\lambda x. \lambda y. \text{LOC}(\mathbf{between}'(y),x) \wedge \mathbf{galaxy}'(y)) \\ & (\mathbf{travel}') \\ \text{c.} \quad & = (\lambda z. \exists y. \text{LOC}(\mathbf{between}'(y),z) \wedge \mathbf{galaxy}'(y) \wedge \mathbf{travel}'(z)) \end{aligned}$$

The appropriate interpretation is obtained without having to postulate any spurious structure or additional device such as the Copy Principle once proposed by Corbin (1987: 136).

## 6. Conclusion

This paper is a first attempt to propose an explicit compositional account of the semantics of denominal adjectives. It puts forward three main ideas : (i) the semantic representation of denominal adjectives is identical to that of their base-noun; (ii) the morphological operations by which complex lexemes are built change the semantic / categorial nature of the lexeme they apply to and the type of the latter keeps trace of this change at each step of the derivation; (iii) interpretive rules at the NP level attune to this information and adapt the interpretation in consequence.

One of the conclusions that can be drawn from the discussion carried out in this article is that the interpretation of NPs with a denominal adjective can be accounted for in a large part on the basis of the relation supplied either by the head noun or the base noun.

In comparison with previous approaches, most notably Corbin (1987, 1990), the present account shifts from a segmental analysis to a semantic one, a move which is in keeping with the interpretive nature of the phenomenon in question. This move has been possible because a lexematic framework has been adopted, which allows things to be stated in a much simpler way than in a morphemic framework. It seems fair to say that the latter does not permit to give a compositional analysis of the meaning of denominal adjectives without adding a lot of artefactual devices. In this respect, the present account allows us to definitely get rid of the Copy Principle, which raises more problems than it solves (Fradin 1996).

However many issues remain to be settled: the semantic types / sorts attributed to the

lexical items have to be justified more thoroughly and the hierarchy they constitute made explicit; the interpretive rules are given piecemeal; neither the reason why they pick up the external vs. the internal meaning nor the way they combine them follows in a principled way from general properties; the conditions that trigger these rules are just postulated instead of being motivated. All these shortcomings remind us that this work is just a beginning and that many examples have to be analysed in detail before we can discover the generalisations at stake behind the phenomena in question.

## Abbreviations

A = adjective, AZR = adjectivizer, DAC = denominal adjective construct, NPDA = noun phrase with denominal adjective, F = feminine, M = masculine, N = noun, SG = singulier, PFX = prefix.

## References

- Amiot Dany. 1997. *L'antériorité temporelle dans la préfixation en français*. Villeneuve d'Ascq: Presses Universitaires du Septentrion.
- Corbin Danielle. 1987. *Morphologie dérivationnelle et structuration du lexique*. 2 vols. Lille: Presses Universitaires du Septentrion. Original edition, Tübingen: Niemeyer.
- Corbin Danielle. 1990. Homonymie structurelle et définition des mots construits. In *La définition*, J. Chaurand & F. Mazière (eds). Paris: Larousse. pp. 175-192.
- Dowty David R. 1979. *Word Meaning and Montague Grammar*. Dordrecht / Boston / London: Reidel.
- Flaux Nelly & Danièle Van de Velde. 2000. *Les noms en français. Esquisse de classement*. Paris / Gap: Ophrys.
- Fradin Bernard. 1996. On morphological entities and the Copy Principle. *Acta linguistica Hungarica* 43 (1-2), pp. 111-151.
- Fradin Bernard. 2003. *Nouvelles approches en morphologie*. Paris: Presses Universitaires de France.
- Fradin Bernard. 2007. Three puzzles about denominal adjectives in **-eux**. *Acta Linguistica Hungarica* 54 (1), pp. 3-32.
- Fradin Bernard. 2008 (to appear). Les adjectifs relationnels et la morphologie. In *La raison morphologique. Hommage à la mémoire de Danielle Corbin*, B. Fradin (ed). Amsterdam / Philadelphia: John Benjamins. pp. 67-89.
- Godard Danièle & Jacques Jayez. 1993. Towards a proper treatment of coercion phenomena. In *Proceedings of 6th EACL 1993*. pp. 168-177.
- Jensen Per Anken & Carl Vikner. 2002. *The English Prenominal Genitive and Lexical Semantics*. Manuscript Engstien / Copenhagen.
- McNally Louise & Gemma Boleda. 2004. Relational adjectives as properties of kinds. In *Empirical Issues in Formal Syntax and Semantics*, Vol. 5, O. Bonami & P. Cabredo Hofherr (eds). Paris: CNRS & Université de Paris 7. URL, <http://www.cssp.cnrs.fr/eiss5>. pp. 179-196.
- Mezhevich Ilana. 2004. English Compounds and Russian Relational Adjectives. In *Proceedings of the North Western Linguistic Conference 2002*: URL, <http://hdl.handle.net/1892/87>. pp. 95-114.
- Partee Barbara H. & Vladimir Borschev. 2001. Some puzzles of predicate possessives. In *Perspectives on Semantics, Pragmatics and Discourse: A Festschrift for Ferenc Kiefer*, I. Kenesei & R. M. Harnisch (eds). Amsterdam / Philadelphia. pp. 91-117.
- Partee Barbara H. & Vladimir Borschev. 2003. Genitive, relational nouns, and argument-modifier ambiguity. In *Modifying Adjuncts*, E. Lang, C. Maienborn & C. Fabricius-Hansen (eds). Berlin / New York: Mouton / De Gruyter. pp. 67-112.
- Pustejovsky James. 1995. *The Generative Lexicon*. Cambridge (Mass.): MIT Press.
- Sag Ivan & Thomas Wasow. 1999. *Syntactic Theory. A Formal Introduction*. Stanford: CSLI Publications.
- Thornton Anna. 1999. On Italian derivatives with antesuffixal glides. *Yearbook of Morphology* (1998), pp. 103-126.